

TSE AUGIER

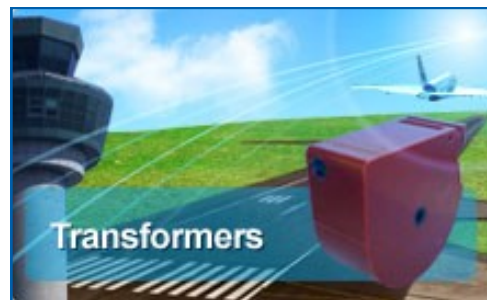

Conforms to Specifications :

ICAO : Airfield conception manual 5th part.
IEC : 61823



Applications :

The TSE is an insulating transformer designed for airport lighting circuits supplied by a constant current regulator.



Advantages :

The TSE transformer is composed of a toroidal magnetical circuit on which primary and secondary windings are separately winded in order to obtain very good electrical performances and a very good dielectric handling.

The whole is embedded in epoxy resin, which drives the transformer to be perfectly watertight and immersible.

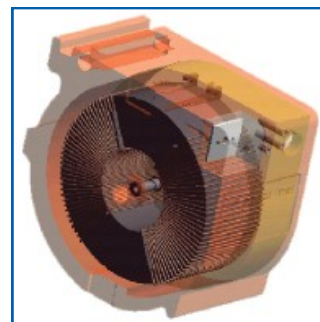

TSE transformers are stackable, primary circuits being directly put in series through their connector using plug devices.

The whole of the assembled device is presented on a support allowing a direct mounting on a HALFEN rail without any additional piece.



The absence of cables gives more room in the pits, so electrical circuits are easier to identify.



Connexions :

Standard, TSEs are delivered with an axial connexion kit. However, in several pits, this type of connexion can be inadapted due to the lack of room. A radial kit is available as an option.

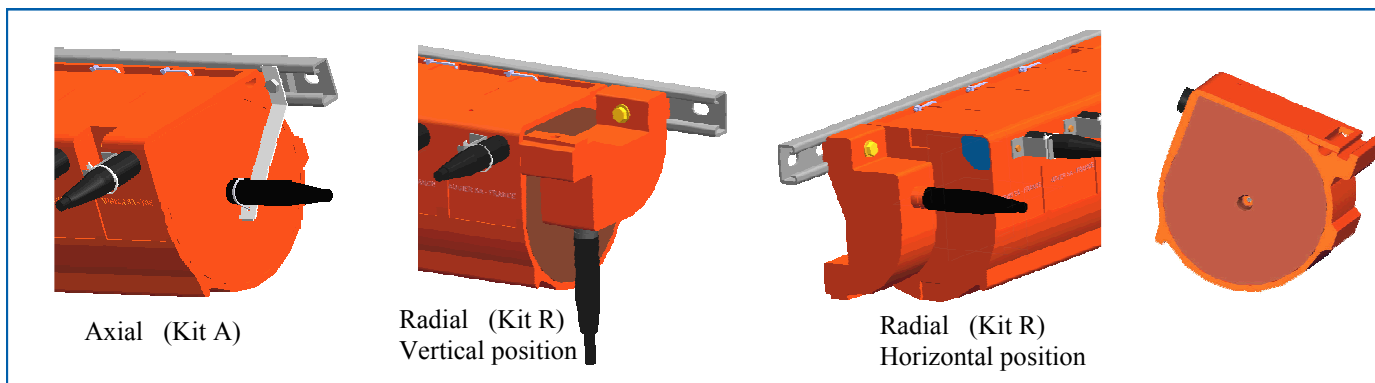

Electrical Characteristics :

- Power Ratings** : 45-65-100-150-200W
- Higher ratings** : by stacking 2 (or more) (conncted in series) above transformers
- Ratio** : 6,6A/6,6A
- Electrical Conformity** : IEC 61823
- Dielectrics** : Primary 10k V ca
- Size** : Length: 92 mm, Height: 184 mm,
Depth: 191 mm, Weight: 7 kg (approx.)

Mechanical Characteristics :

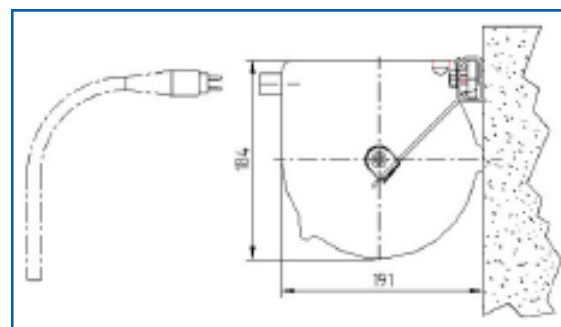
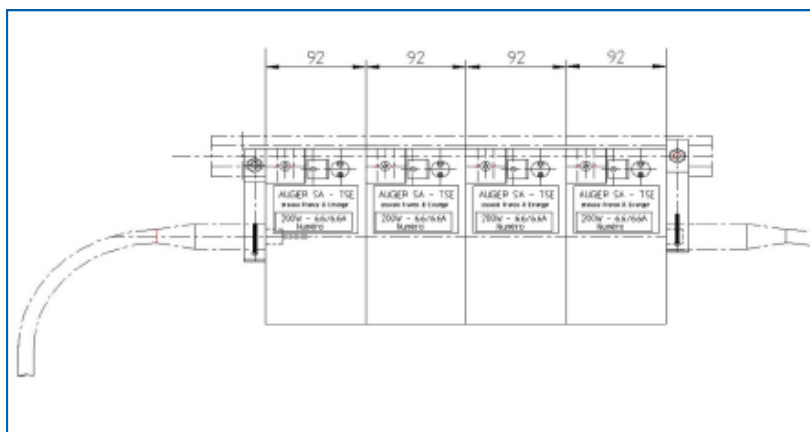

Nominal Power Va	Using Power Va	Length (mm)	Width (mm)	Height (mm)	Weight (kg)
60	45	92	191	184	7
85	65	92	191	184	7
130	100	92	191	184	7.2
185	150	92	191	184	7.4
240	200	92	191	184	7.4

AUGIER IS CERTIFIED ISO 9001 SINCE 1995



AUGIER SAS
ZI CARROS 1ère avenue 2243m
BP 131 - 06513 CARROS Cedex
FRANCE

Tél : +33 (0) 4 92 08 62 00
Fax : +33 (0) 4 93 29 01 40
home@augier.com
www.augier.com



A WORLD OF ENERGY UNDER CONTROL
UN MONDE D'ÉNERGIE MAÎTRISÉE

